

# MS1200 Oil in Water / Fuel in Water Monitor

## Product Description

The MS1200 is a VOC / Hydrocarbon Concentration Monitor designed for water supply protection, process control and waste water outflow monitoring.

It utilises a contactless measurement technique, sensing headspace gases or volatiles providing a measurement system requiring **NO REAGENTS OR GASES** and with **very low maintenance requirements**.

The MS1200 is accurate to low ppb concentrations and its wide dynamic range allows it to be used in a wide variety of environments.



## Applications

- Protection of Surface Water Intakes
- Monitoring of Ground Water and Boreholes
- Oil and Fuel Leak Detection
- Water Treatment Process Monitoring
- Land Remediation

## Benefits

- Low maintenance costs
- High reliability
- No reagents
- Field proven technology

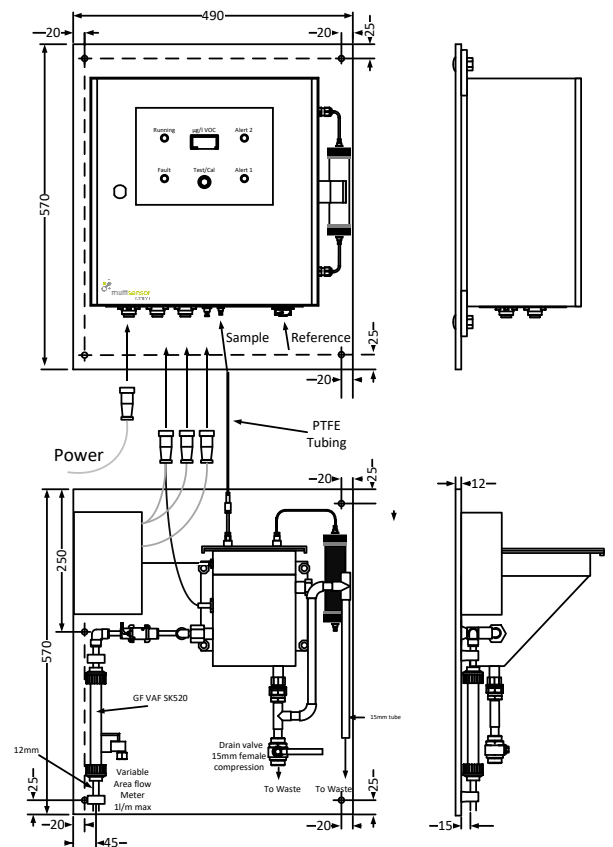

## BACKGROUND

The Multisensor Systems MS1200-01 is a high sensitivity, broadband Monitor for Volatile Organic Compounds (Also referred to as Oil in Water Monitor or Hydrocarbon Monitor). It is adapted for applications in the water industry, measurement of industrial discharges and environmental management.

## PRINCIPLE OF OPERATION

The principle of operation is the measurement of headspace gases from a sample tank containing the water to be measured. Through the use of Henry's Law the concentration of gases in the headspace is proportional to the concentration of the substance in the water.

Calibration of the instrument is done by presenting known concentration to the sensors and generating calibration coefficients from the responses obtained.

The MS1200 works by passing water through a sample tank as shown below. The volatile components in the water will pass into the headspace above the water where they will be trapped. This will continue until equilibrium is reached.

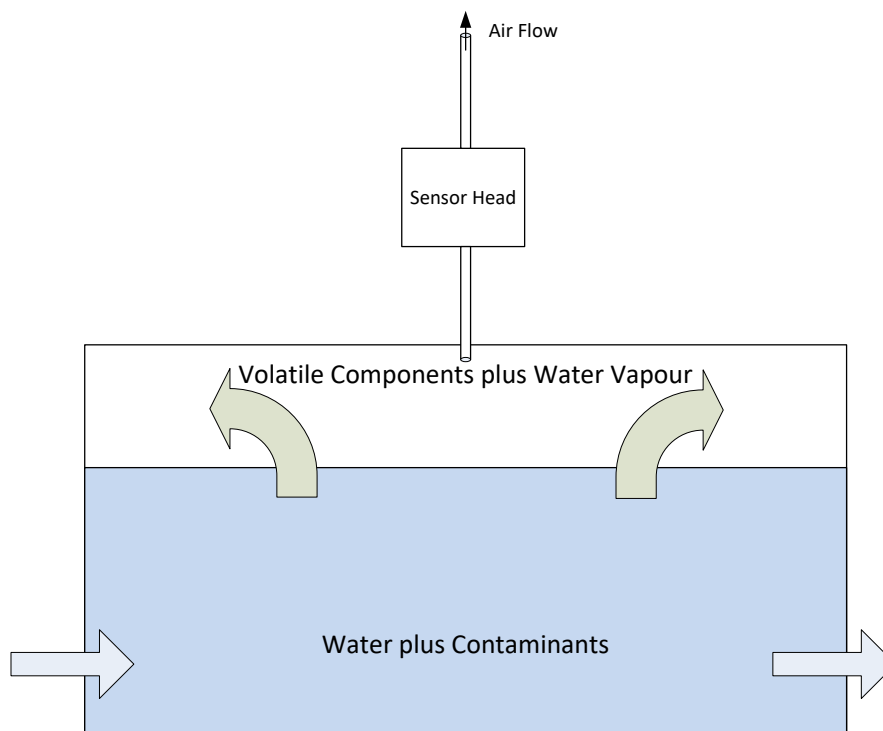

A sample of the headspace gases are then passed across sensors in the MS1200 sensor head which respond to the Volatile Organic Compounds (VOCs) in the headspace. This response is then analysed by the instrument and a concentration value is generated based upon the relationship between the concentration present in the headspace and that in the water.

## CALIBRATION

For the detailed calibration technique see MS1200 Operation and Maintenance Manual. The technique is to present standards of Toluene in water to the instrument. Calibration is then done either automatically by the instrument or can be done manually.

Validation of systems in the field is achieved using the Multisensor Validation Kit which presents a standard concentration to the instrument.

## TYPICAL PERFORMANCE

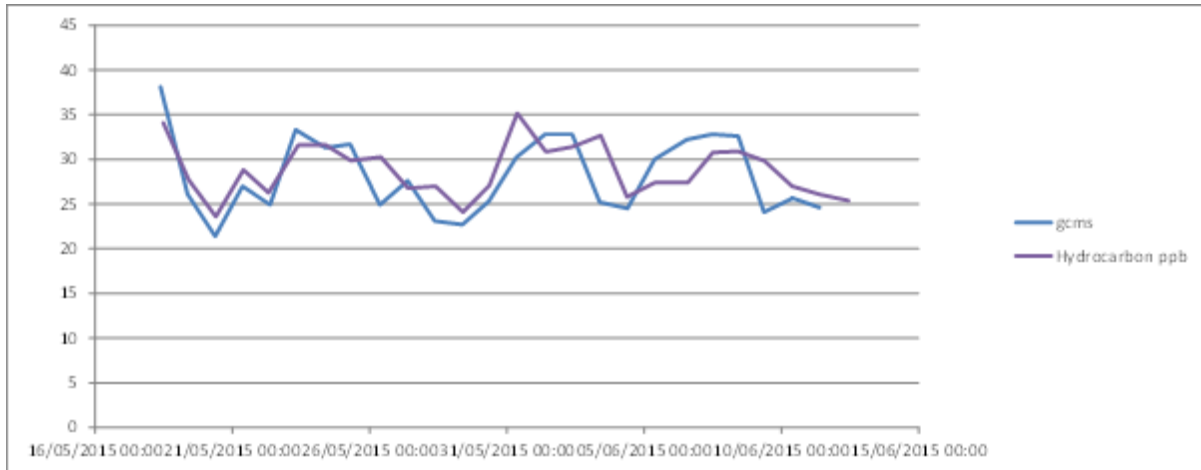

Typical response compared to GCMS measurement from a certified laboratory.

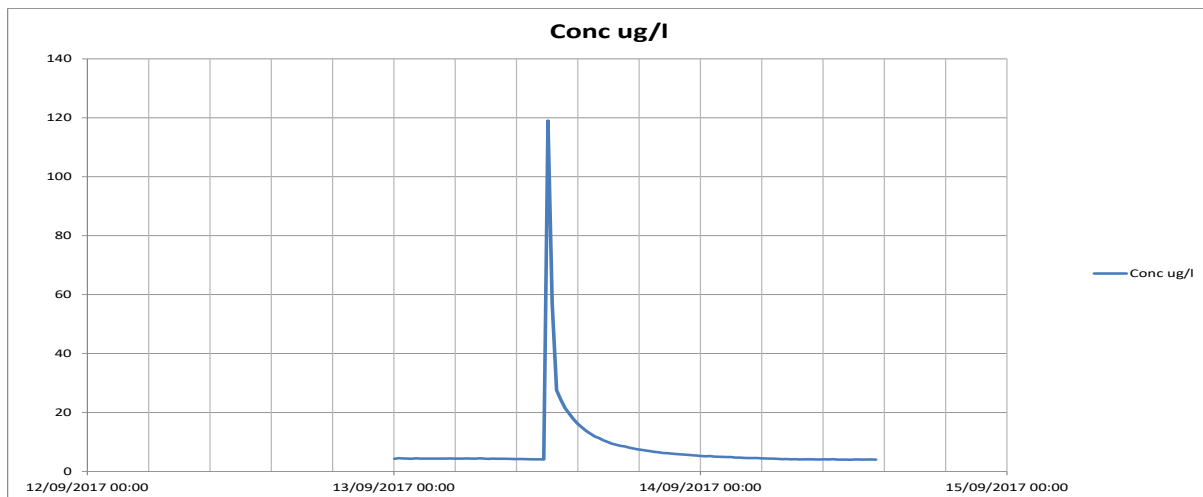

Short term event showing rapid rise and gradual fall of concentration.

## KEY PERFORMANCE PARAMETERS

Parameter	Operational Requirements		Notes
	Minimum	Maximum	
Power	90V AC	240V AC	50Hz or 60Hz
Power Consumption		15W	Typical 10W during operation
Water Supply	0.5 l/min	1.0 l/min	
Water Pressure		4.0 bar	
Working Temp: Ambient	0C	40C	Higher temperature available
Working Temp: Water	1C	40C	Higher temperature available
Sampling Period	10mins	120mins	User selectable. High concentrations may limit the minimum time period allowed
Instrument Case	IP65, Coated Mild Steel		
Sample Tank Material	316 Stainless Steel		Other materials and coatings available

Parameter	Performance Limits		Notes
	Minimum	Maximum	
Detection range	1ppb	3000ppb	Measured against Toluene standard. For calibration using other compounds contact Multisensor Systems
Repeatability	-2%	+2%	200ppb sample measured using standard 1.5l solution (Water plus Toluene dissolved in DMSO) in glass 2.5l Winchester type bottle using magnetic stirrer at 25C
Display range (Default)	0ppb	1000ppb	Configurable on commissioning
Analogue Output	4mA	20mA	Scalable to range required, max load 900R
Analogue Output Isolation	400V		Continuous. Opto-isolated.
Relay Voltage		50V	2x, Alarm 1 and Alarm 2 Relays with NO and NC contacts
Relay Current		5A	
Flow Switch	Contacts closed if flow below set point		Option available on request
Weight	25kg		
Dimensions	1170 x 490 x 300mm		Mounted on 2 separate PVC backboards

## Validation Period

**6 Months - using Calibration Kit available from Multisensor Systems or Authorised Distributor**

## Consumables

**Every 6 Months: Active Carbon Air Filter Contents  
Dust Filter Element**

**Every 12 Months: Sample Tank gasket**